

# FEM 5000S/ F/ G

## Electro-Magnetic Lock

### Introduction:

- The FEM 5000S/ F/ G electromagnetic is specifically designed for exterior application with the lock casing made of stainless steel.
- FEM 5000S is side mounted with the wire exit opposite to the mount, FEM 5000F is face mounted with the wire exit opposite to the mount. The FEM 5000G can be either side or front mounted with wire exit on the head end. Voltage spike suppressor are embedded inside the electromagnetic lock to compensate unwanted high voltage spikes.
- The lock has no residual magnetism and opens instantly upon power isolation.
- The electromagnetic lock should always be mounted on the secure side of the door.

### Power setting and Input

#### 12 VDC/ 0.48 A



#### 24 VDC/ 0.24 A

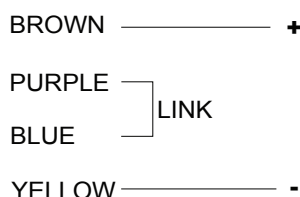

#### REED SWITCH SENSOR

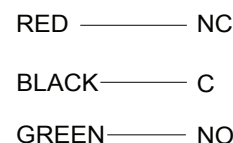

Warning: Misconnection of wiring will cause the MOV surge suppression inside the electromagnetic lock to fail. This will not be covered under warranty.

On DV option, there is no status sensor.

On LSS option, the magnetic lock has a built-in reed switch for remote lock monitoring status (Open or Closed) on three output wires:

RED wire (Normally closed); Reed Switch not Operated-	Black wire (Common) No Power on magnetic lock. Power on magnetic lock and door Open.	Green wire (Normally open) Power on magnetic lock and door Closed.
Reed Switch Operated-	Power on magnetic lock and door Closed.	

The Reed Switch contacts are rated at 24 volts at 0.2 ampere maximum.

### Installation Tips

The FEM 5000S/ F/ G is critical to secure the magnetic lock firmly on the door frame to avoid loosening screws and causing possible injuries.

#### Armature plate must remain flexible

The armature plate must remain movable to allow surface alignment with the magnet face. The magnetic lock will lose holding force without floating alignment.

#### Do not trim the rubber washers

Trimming rubber washers will adversely effect the operation of magnetic lock.

### Important Safety Requirements

1. Apply thread-locker glue (i.g. Loctite) to the thread of the Armature-Plate-Fixing Screw (Allen-Screw) to prevent from becoming loose.
2. Locks should be inspected at regular intervals to ascertain the safety functionality in conjunction with the door environment.
3. The supplied Allen screws cater for maximum door-thickness of 45mm.

## Trouble Shooting

Problem	Possible Cause	Solution
Door will not lock	No DC voltage to lock.	Check power supply and wiring to magnetic lock.
Reduced holding force	Bad physical contact between armature plate and face of magnet.	Ensure mating surfaces are clean and in proper alignment and the armature plate floats freely.
Reed Switch Status is incorrect	Low voltage or wrong voltage setting	Correct to desired voltage setting and power input requirement

## Maintenance

Contacting surface of the electro-magnet and Armature plate must be kept free of contaminating materials. Surfaces should be cleaned periodically with a non-abrasive cleaner. Do not spray the electro-magnet and armature plate surface with any chemicals such as lacquer, etc. This will create problems with the release of the armature plate from the magnetic lock and can cause serious safety problems.

## Sample of Mounting Procedure

### 1. Sliding Door Installation

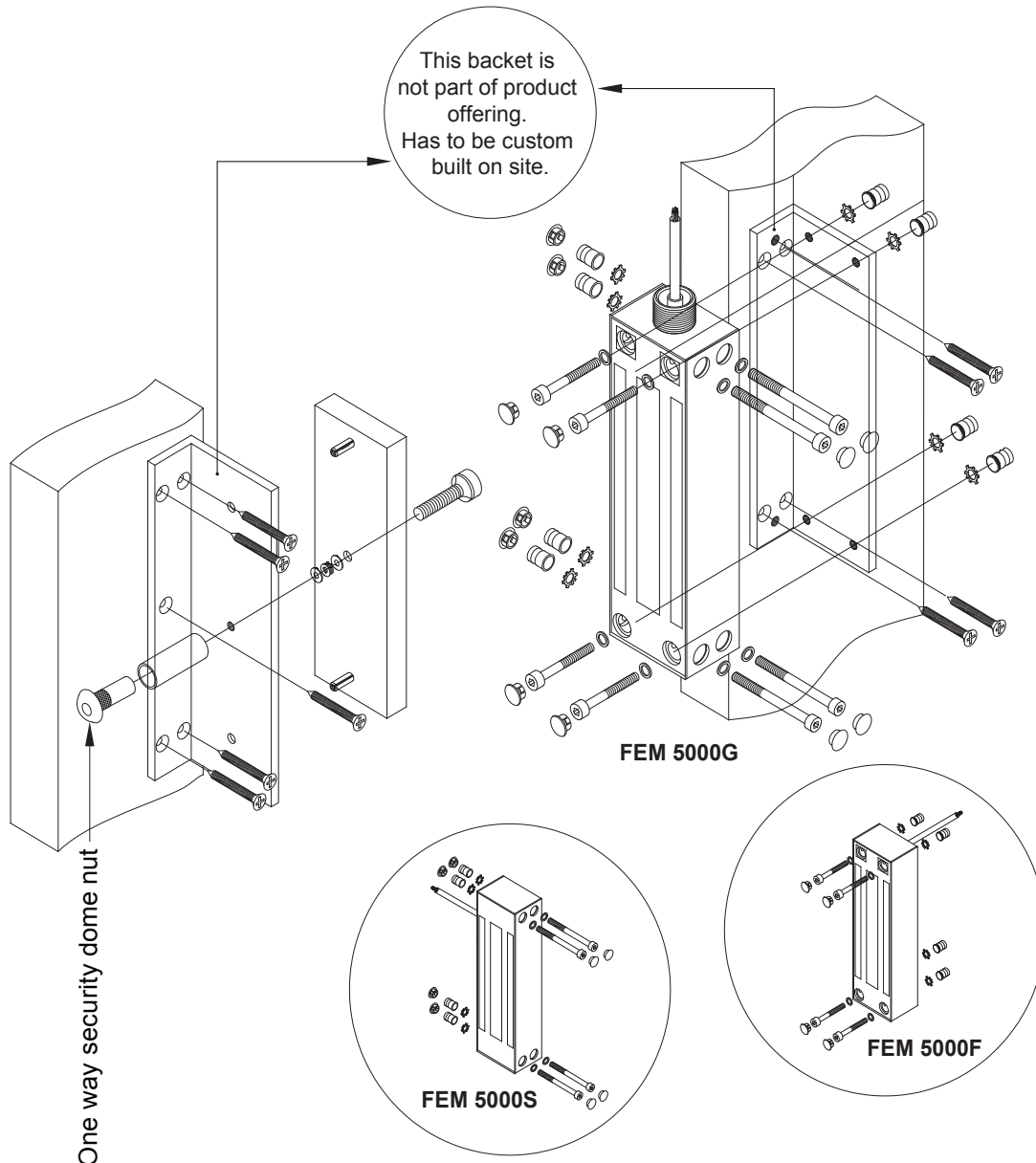

## 2. HINGED-DOOR INSTALLATION

### TYPICAL FIXING OF MAGNETIC LOCK ON IN-SWINGING DOOR

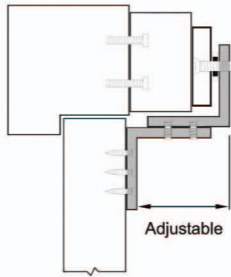

Z BRACKET ARRANGEMENT FOR INWARD SWINGING DOOR

### ARMATURE MOUNTING PLATE DETAIL

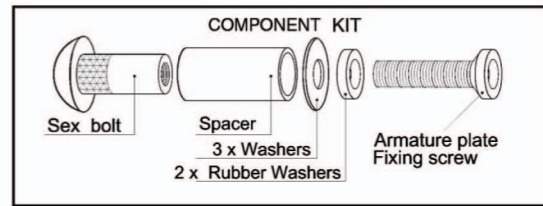

ARMATURE PLATES MUST BE INSTALLED WITH THE COMPONENTS SHOWN ABOVE. THESE COMPONENTS ARE PROVIDED WITH EACH ELECTROMAGNETIC LOCK. (TO AVOID MALFUNCTION OF THE LOCK DO NOT USE PARTS OTHER THAN THOSE PROVIDED ABOVE).

### TYPICAL FIXING OF MAGNETIC LOCK ON OUT-SWINGING DOOR

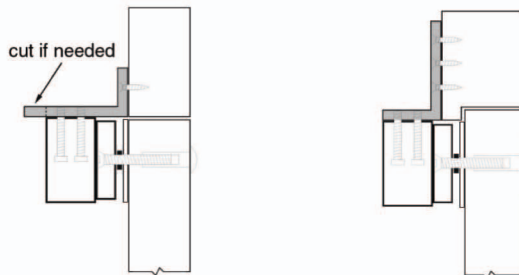

ADJUSTABLE L BRACKET  
Adjustable L Bracket is for Flush Transom or Narrow Header.

L BRACKET ARRANGEMENT  
L Bracket is for Narrow Header.

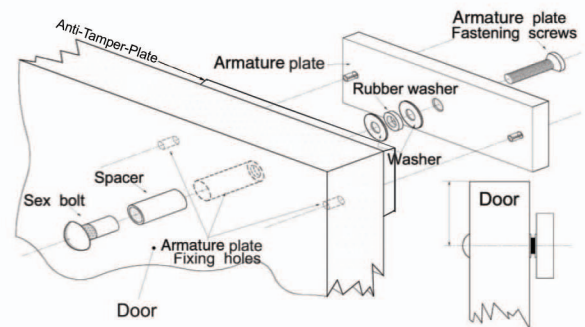

ARMATURE PLATES MUST BE FIXED AS SHOWN ABOVE. DO NOT OVER TIGHTEN THE FIXING SCREW. THE ARMATURE MUST BE ALLOWED TO 'FLOAT' ON THE RUBBER WASHER.

### METHODS OF FIXING MAGNETIC LOCKS ON DIFFERENT FRAME PROFILES

