



# Electromechanical Locking Solutions

Side Load Locks,  
Drop Bolts,  
Electric Strikes,  
Electromagnetic  
Locks, Roller Door  
and Gate Locks,  
Cable Transfers

# Symbols



CE Rated  
Complies with the requirements of the relevant European health, safety and environmental protection legislation



Fire Rated  
Denotes that the product has been successfully tested on fire door assemblies by independent laboratories



C-Tick Approved  
Applies to electrical and electronic devices, indicating compliance with relevant labelling notices and product standards



**Two strong global brands—Dorma and Kaba – have combined forces and are now offering you a comprehensive portfolio of smart & secure access solutions, all from one, reliable source.**

Our new product portfolio includes everything from locks and keys to a fully networked electronic access solution, and everything from door closers and automatic doors to a mobile partition system.

All supported by a comprehensive service network.

# Table of contents



01 Side Load Locks



02 Drop Bolts



03 Electric Stikes



04 Electromagnetic Locks



05 Roller Door and Gate Locks



06 Cable Transfers

# KES1500

## Rim Mounted Electric Strike

The KES1500 Series Rim Mounted Electric Strike is an economical choice, offering dual voltage 12/24V as standard and an interchangeable fail safe/fail secure feature.

It is constructed of a solid zinc alloy housing, stainless steel keeper and stainless steel face plate. Designed for use with a large selection of rim mounted lock types. Suitable for wood framed and hollow metal doors.

### Features

- Fail safe/fail secure interchangeable
- Dual voltage 12/24V
- Suits latch depth up to 15mm
- Holding force: up to 900kg (2000lb)



### Specifications

Lock	62L x 86W x 28.5D (mm)
Operating voltage	12/24VDC
Voltage tolerance	+/-15%
Current draw	0.25 A/12VDC: 0.15 A/24VDC (at temperature 20°C)
Operating temperature	-10° C ~ +45°C
Humidity	0-95% non-condensing
Cycle Tested	to 1 million cycles
Material	Zinc alloy body stainless steel faceplate & release lip

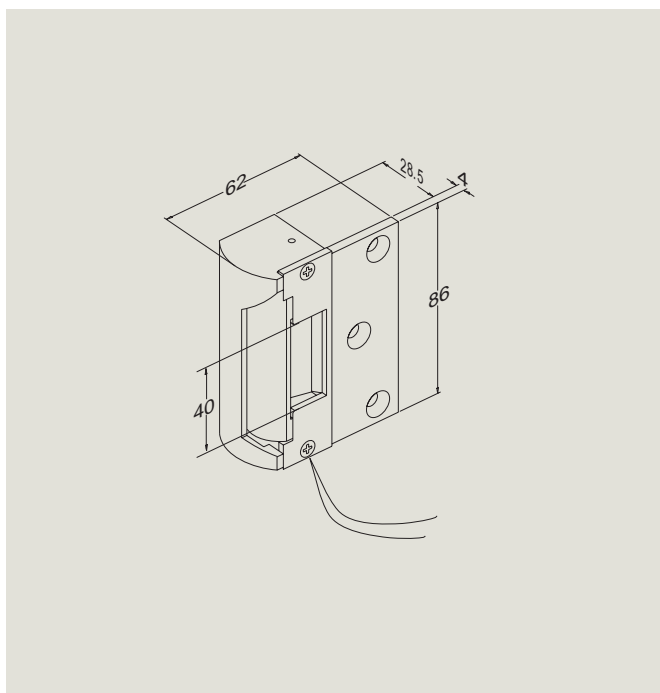

Dimensions - Lock

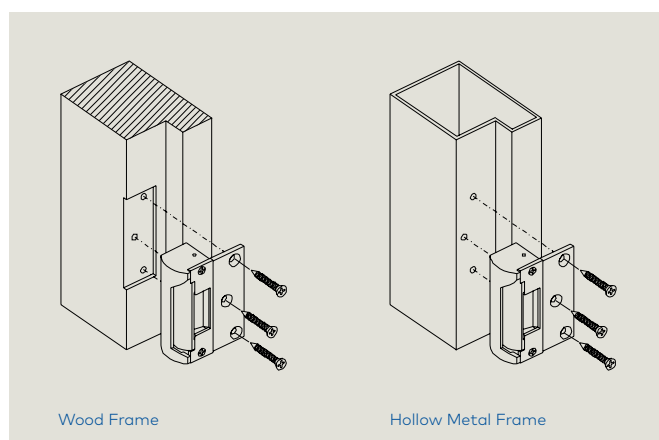

Typical Installation

Part No.	Description
KES1500	Rim Mounted Electric Strike 12/24VDC, Non Monitored

# Electric Strikes

## Accessories



**KESLP125**  
Lip Extension 25mm



**KESLP150**  
Lip Extension 50mm



**KESLP2225**  
Lip Extension 25mm



**KESLP2250**  
Lip Extension 50mm

Part No.	Description
KESLP125	Lip Extension 25mm, suit KES100
KESLP150	Lip Extension 50mm, suit KES100
KESLP2225	Lip Extension - 25mm, suit KES2200 Electric Strike
KESLP2250	Lip Extension - 50mm, suit KES2200 Electric Strike





[www.dormakaba.com.au](http://www.dormakaba.com.au)

dormakaba - Electromechanical Locking Solutions Brochure. MAR/18  
Subject to change without notice

dormakaba Australia  
Head Office  
46-52 Abbott Road  
Hallam VIC 3803  
T: 1800 675 411  
[info.au@dormakaba.com](mailto:info.au@dormakaba.com)  
[www.dormakaba.com.au](http://www.dormakaba.com.au)

dormakaba New Zealand  
Head Office  
Building P, 61-69 Patiki Road  
Avondale, Auckland 1026  
T: 0800 436 762  
[info.nz@dormakaba.com](mailto:info.nz@dormakaba.com)  
[www.dormakaba.co.nz](http://www.dormakaba.co.nz)