



Electromechanical Locking Solutions

Side Load Locks,
Drop Bolts,
Electric Strikes,
Electromagnetic
Locks, Roller Door
and Gate Locks,
Cable Transfers

Symbols



CE Rated
Complies with the requirements of the relevant European health, safety and environmental protection legislation



Fire Rated
Denotes that the product has been successfully tested on fire door assemblies by independent laboratories



C-Tick Approved
Applies to electrical and electronic devices, indicating compliance with relevant labelling notices and product standards



Two strong global brands—Dorma and Kaba – have combined forces and are now offering you a comprehensive portfolio of smart & secure access solutions, all from one, reliable source.

Our new product portfolio includes everything from locks and keys to a fully networked electronic access solution, and everything from door closers and automatic doors to a mobile partition system.

All supported by a comprehensive service network.

Table of contents



01 Side Load Locks



02 Drop Bolts



03 Electric Stikes



04 Electromagnetic Locks



05 Roller Door and Gate Locks



06 Cable Transfers

KES2200

Fully Monitored Electric Strike

The KES2200 Series is a high security electric strike, offering a single model including switch monitoring of latch, keeper and solenoid, variable voltage from 12VDC/AC to 28VDC/AC, a fast and convenient interchangeable fail safe/fail secure function (changeable on site).

The construction of housing and keeper are of stainless steel and include pre-drilled holes for optional extension lips. Also included in package is an installation kit for metal frame installation.

Features

- Fail safe/fail secure interchangeable
- Variable voltage 12~24VDC
- Suits latch depth up to 15mm
- Monitored latch, keeper and solenoid
- Pre-drilled for optional extension lips
- Includes mounting tabs for metal frame
- Solid stainless steel construction
- Optional Lip extension brackets are available for wide door jamb



Specifications

Lock	175L x 44W x 27D(mm)
Operating voltage	12-24VDC
Voltage tolerance	+/-15%
Current draw	12VDC/190mA, 24VDC/130mA (at temperature 20°C)
Latch/Keeper Micro Switch Rating	1A/125VAC
Operating temperature	-10° C ~ +45°C
Humidity	0-95% non-condensing
Cycle Tested	to 1 million cycles
Material	stainless steel housing and keeper

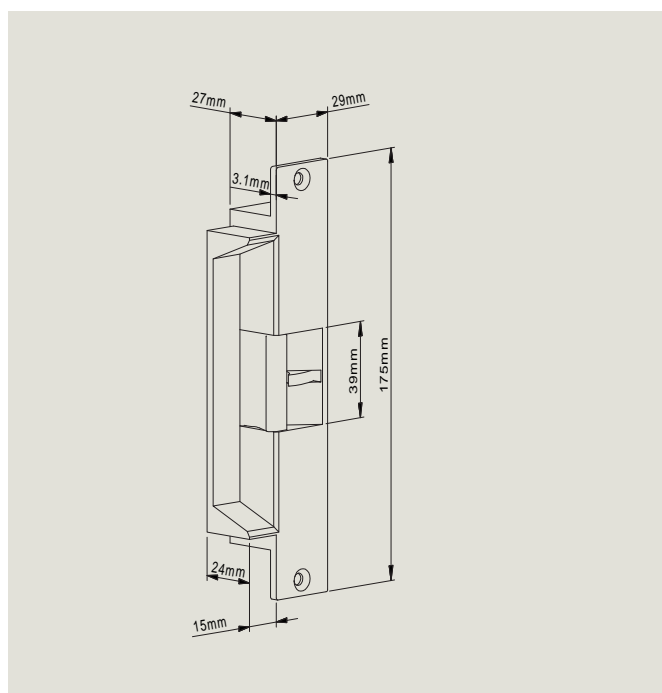

Dimensions - Lock

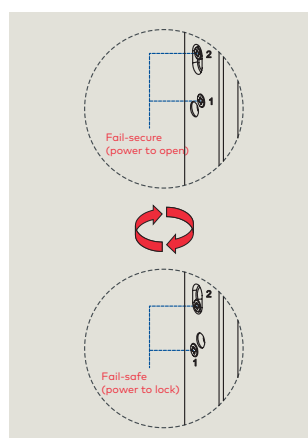

Version Changeable

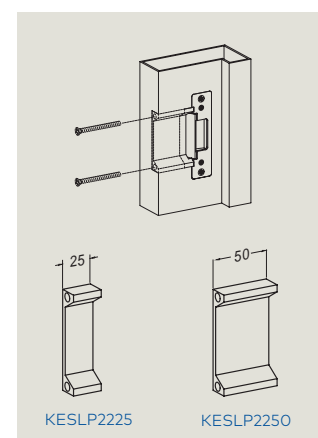

Optional Accessories

Part No.	Description
KES2200	Electric Strike, Heavy duty 12-28VDC/AC, Monitored

Electric Strikes

Accessories



KESLP125
Lip Extension 25mm



KESLP150
Lip Extension 50mm



KESLP2225
Lip Extension 25mm



KESLP2250
Lip Extension 50mm

Part No.	Description
KESLP125	Lip Extension 25mm, suit KES100
KESLP150	Lip Extension 50mm, suit KES100
KESLP2225	Lip Extension - 25mm, suit KES2200 Electric Strike
KESLP2250	Lip Extension - 50mm, suit KES2200 Electric Strike



www.dormakaba.com.au

dormakaba - Electromechanical Locking Solutions Brochure. MAR/18
Subject to change without notice

dormakaba Australia
Head Office
46-52 Abbott Road
Hallam VIC 3803
T: 1800 675 411
info.au@dormakaba.com
www.dormakaba.com.au

dormakaba New Zealand
Head Office
Building P, 61-69 Patiki Road
Avondale, Auckland 1026
T: 0800 436 762
info.nz@dormakaba.com
www.dormakaba.co.nz